

ULTRA FAST CIRCUIT BREAKER

FABUNMI TIMILEYIN.S, FOLORUNSO OLADIPO, OJO O. ADEDAYO

DEPARTMENT OF ELECTRICAL/ELECTRONIC AND COMPUTER ENGINEERING, AFE BABALOLA
UNIVERSITY, ADO-EKITI, NIGERIA

ABSTRACT: Electronic devices are made to operate on very low voltage; therefore a means of proper protection against overloading, short-circuiting and surging should always be of uttermost priority to the designers. A well designed electronic device with proper protective device would definitely lead to economic benefit, time saver, and less energy to re-construction. This paper reports the design and construction of an Ultra Fast Circuit Breaker (UFCB) for domestic and industrial purposes.

KEYWORDS: Ultrafast circuit breaker, Overload, Over-current, Optocoupler, Relay, Choke resistor

I. INTRODUCTION

The popular method of protection for electrical, mechanical and other forms of energy equipments from overload or short circuit of voltage in an electrical circuit is usually the use of fuses which is normally attached to the extension power supply or at the end of the appliance's plug. In terms of appliances protection advancement, circuit breakers and surge protectors have being of use for proper protection of the appliances, bimetallic strip is used for enhancement in the breakage of the circuit. Electric circuit breakers are found in industries, in their sizes depending on the requirement.

Electricity is one of the world most important form of energy that has being of use for centuries, and will also be in use for a very long time till other form of energy are generated. In the world, it is used by mankind for their personal satisfaction, by industries for powering and operating their machines, it is used at home, offices for powering appliances , electronic equipments and most importantly used in conversion from one form of energy to another. Without electricity, most of the electrically powered machine (industrial) will not operate or work at all. A factor that has hindered and destroyed most of our appliances

(both at homes and office), industrial machine and equipments, is the problem of high voltage power surge.

It is required that energy be controlled and conserved for use at all possible cost. Electrical energy is required to be available at all time for use. The lack of quality, efficient control and conservation has hindered the equality of power and its distribution in most developing countries (Nigeria especially).

II. HISTORICAL BACKGROUND OF CIRCUIT BREAKERS

Circuit Breaker was invented over hundred years ago. It was first described by Thomas Edison (1900) as fuse used by his commercial power distribution. The initial reasons for developing the circuit breaker was to protect the lighting circuit wiring from impulse short-circuit and overload (Isreal, 1986). Advancement in the circuit breaker technology was done with the advance in general technology. It advancement include the modern miniature circuit breakers similar to those used currently and it was patented by Brown and Boveri over 90 years ago (1924). As time pass, requirement for various other types were created due to advancements, for instance, the thermal magnetic breaker which is still in use till date was created by (Stotz,

2006), who advanced on the low voltage circuit breakers with the introduction of the thermal and thermal magnetic circuit breakers.

As a result of miniaturization in Circuit breaker technology advancement, with respect to the required satisfaction of electronics compactness, it has being created to be easily portable and compactable with simple and complex electronic designs, electrical circuit and appliances.

Without circuit breakers (or the alternative, fuses), household electricity would be impractical because of the potential for fires and other mayhem resulting from simple wiring problems and equipment failures (Harris, 2015).

According to (Mohankumar, 2013), “Electrical circuit breaker is a device that senses an overload and short circuit condition, then breaking the circuit to protect the system or circuit from damages or breakdown”. It is an ideal circuit to protect uninterrupted power supply like inverter (D.Mohankumar, 2013).

Circuit breakers are in varying sizes from small devices that protects and individual household appliances up to large switch gear for high voltage circuits. They are used for fault interruption in both D.C and A.C currents.

According to (Santoso, 2012), “Existing and proposed techniques for interrupting DC fault current utilize electromechanical circuit breakers (EMCBs), solid state switches and their combination in DC systems . It is proposed to generate artificial current zero in

the arc by superimposing a counter flow of current, for an oscillating circuit evoked only during circuit breaking. Solid state circuit breakers make use of power electronic switches for interrupting the current without arcing (Santoso, 2012). Disadvantages of solid state circuit breaker are the absence of galvanic isolation and lack of the same withstand against transient over voltage. Even though the type of circuit breaker allow for very high interruption speeds, existing protection relays typically do not use this feature (Santoso, 2012). Relays associate with converters are used to detect and clear faults in a Direct current distribution system.

III. ULTRA FAST ELECTRICAL CIRCUIT BREAKER

Ultra fast circuit breaker is an advanced, more effective and reliable circuit breaker. This circuit breaker is different from the ordinary circuit breakers such as the miniature circuit breaker that makes use of the temperature nature and property of thermal bimetallic strip, to trip off when there is an overload or short circuit. The ultrafast circuit breaker makes use of comparator(s), series elements depending on the appliances on which they are to be installed, micro-controller and some other devices to perform its ultra fast tripping process (Ravi, 2013).

IV. METHODOLOGY

The methods involves are summarized in the block diagram of figure 1.

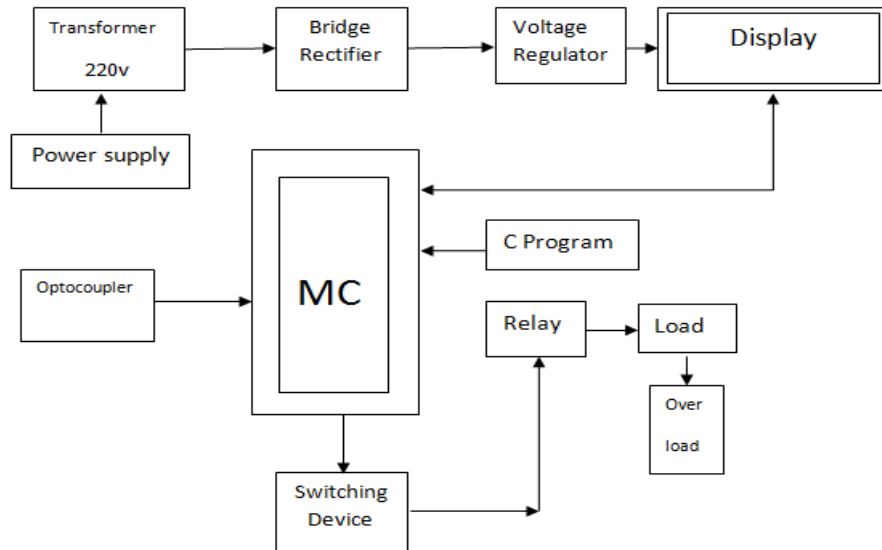

Figure 1: Block diagram of the operation processes and design methods of the UCB

The Ultra Fast Circuit Breaker has 5 major sections which are as follows:

1. Power Supply Section
2. Comparator Section
3. Microcontroller Section
4. Relay Tripping Section
5. Output Section

V. OPERATION OF ULTRA FAST CIRCUIT BREAKER

The 220/12V, 500mA transformers, bridge rectifiers, 2200 μ F capacitors, 470 μ F capacitors, voltage regulator are all connected to microcontroller and the opto-coupler, these are used for the monitoring and control of the circuit condition at no load, load and over load. The relay is connected to one end of the load and the other end going to the comparator circuit along the life wire (supply). The circuit is powered by the 220/12V, 300mA transformer, then the bridge rectifier, the voltage regulator supply the necessary 5V to the microcontroller and as well, the optocoupler. The LCD is also powered by the 5V and the back light contrast are controlled

with a variable resistor between pin 1 and 3. The LCD displays the information about the system and indicate that the system is ready for load.

On loading with a single 60W lamp, the LCD displays the condition of the UFCB as "normal loading". Here, the system operates properly until the second 60Watt lamp is added. The optocoupler sends a signal to the microcontroller. The microcontroller in 1 μ sec sends electrical signal to the relay, which in turn actuated the trigger from normally closed to normally open and the buzzer is activated immediately. The system switch off the 2 lamps and the LCD displays an overload condition of the system. The overload (a lamp) is then removed and the reset button is pushed, then the switch is pushed for the lamp to be on. This process is repeated for the various times there is an overload present in the system.

The following tests were involved in the operation of the circuit to determine its overall performance after casing with a transparent plastic:

1. Start up time and No-Load test

2. Load test
3. Overload test

VI. RESULTS

The tripping circuit was able to switch ON and OFF the system loads when there is an over current or overload. The timed relay circuit with the microcontroller worked satisfactorily within 1µsecs. The buzzer alarm to indicate when there is an overload with the tripping process worked satisfactorily. When the system loads are off, the reset switch is off and then pushed on, to activate the single load on, after the overload is eliminated. Measured results are given as: 4.7ohms of Choke resistor, 220V (A.C) from source, Microcontroller voltage measured between VCC and GND is 4.93V, LCD voltage measured between pin VCC (2) and GND (5) is 4.91V. Also the lamps voltage measured 2.13V for lamp 1 and 3.15V for lamp 2. Voltage difference = 1.03V. The tripping time and shutdown of the system when there is any form of over current is approximately 1microsec.

VII. BENEFITS

The benefits of UFBC includes

1. To provide a cost effective and reliable circuit breaker that response to very little over current that can damage some of our electronics if not properly protected.
2. To provide solution to the high rate of damage to our appliance in remote areas of Nigeria.
3. To provide lots of benefit from its use in numbers, which includes; industrial machines, heavy and light office equipments and home appliances.

VIII. RECOMMENDATIONS

The UFCB has performed as desired according to the design objectives. We hereby make the following recommendations for improving on this UFCB designed in Afe Babalola University, Ado-Ekiti, and Electrical/Electronic laboratory and also for further studies on it.

- a. The use of a 240/12V, 300A transformer for the power supply will also conveniently power the circuit.
- b. The use of a good current sense op amp could be employed on the circuit alongside a PIC microcontroller to obtain the same ultrafast attribute of the circuit breaker.
- c. Solid state switches can also be used for the Ultra Fast Switching.
- d. For larger load capacity the choke resistor can be increased.
- e. For more load to overload ratio the reference voltage set by the controller can be increased, while the overload voltage can also be increased are required.
- f. An uninterrupted power supply can be implemented in the system to enhance and improve its efficiency when there is power shutdown due to faults, over-current or any form of power shutdown.

IX. CONCLUSION

A general view of the different types of the circuit breakers has been presented. It is observed that the benefits offered by the ultra fast circuit breaker for electronics is more than that of some other circuit breakers like low voltage circuit breakers, medium voltage circuit breakers, miniature circuit breakers, oil circuit breakers and fuses.

This UFCB designed has been proven to be very reliable and can be of great use in houses, offices, industrial settings and all

environments where constant power supply are of great importance. With improved rating of the generator more percentage of loads can be placed on them.

REFERENCE

1. Aoyagi, K. (2006, september 18). *Electrical engineering in Japan*. Retrieved May 24, 2015, from wiley Online library: <http://www.interscience.wiley.com/journal/113307491/abstract?CRETRY=1&SRETRY=0>
2. D.Mohankumar. (2013). *Engineering garage*. Retrieved May 12, 2015, from www.engineersgarage.com/contribution/electronic-circuit-breaker
3. Graf. (2014). *Electrical Engineering Blog*. Retrieved june 11, 2015, from eblogbd.com/what-is-opto-coupler-or-opto-isolator
4. Harris, T. (2015). *How circuit breaker works*. Retrieved May 20, 2015, from How stuff works: <http://electronics.howstuffworks.com/circuit-breaker.html>
5. Isreal, R. F. (1986). Edison's Electric Light. *Biography of an Invention* , 65-66.
6. MikroElektronika. (2015). *Mikroelektronika*. Retrieved May 26, 2015, from Architecture and programming of 8051 MCU's: 7. OSHA. (2009, March). *OSHA Construction eTool*. Retrieved May 26, 2015, from OSHA Construction eTool website.: http://www.osha.gov/SLTC/etools/construction/electrical_incidents/gfci.html
8. Ravi, K. (2013). Ultra Fast Electronic Circuit Breaker.
9. Renard. (1999). *Switch*. Retrieved May 24, 2015, from Miniature circuit Breaker: http://bonle.enalibaba.com/protect/50348671/51680889/switch/MCB__MCCB./html
10. Santoso, S. K. (2012). Interrupting Short Circuit Direct Current Using an AC Circuit Breaker in Series with a Reactor. *Advance in Power Electronics. , volume 2012*, 14.
11. Stotz. (2006). Miniature Circuit Breaker and domestic appliances. In Stotz, & a. 5. 2015 (Ed.).
12. Susanto, J. (2013, february 10). *Circuit breakers*. Retrieved may 21, 2015, from Open electrical: [http://www.openelectrical.org/wiki/index.php?title=Circuit breakers](http://www.openelectrical.org/wiki/index.php?title=Circuit%20breakers)